

V A R I A

ÚSTAV DIZAJNU / INSTITUTE OF DESIGN - 1_APD4_D ATELIÉR PRIEMYSELNÉHO DIZAJNU

Téma / topic: Kinestetický dizajn

Pedagóg / pedagogue: Mgr.art. Martin Baláž, ArtD.

Konzultant / consultant: Mgr.art. Martin Baláž, ArtD.

Študent / student: Rebeca Ihringová

Akademický rok / academic year: 2020/2021

Ročník / class: III.



SLOVENSKÁ TECHNICKÁ
UNIVERZITA V BRATISLAVE
FAKULTA ARCHITEKTÚRY A DIZAJNU

VNÍMANIE

utváranie vnemu vzniká pri
odzrkadľovaní sa objektov,
javov a procesov vonkajšieho
a vnútorného sveta

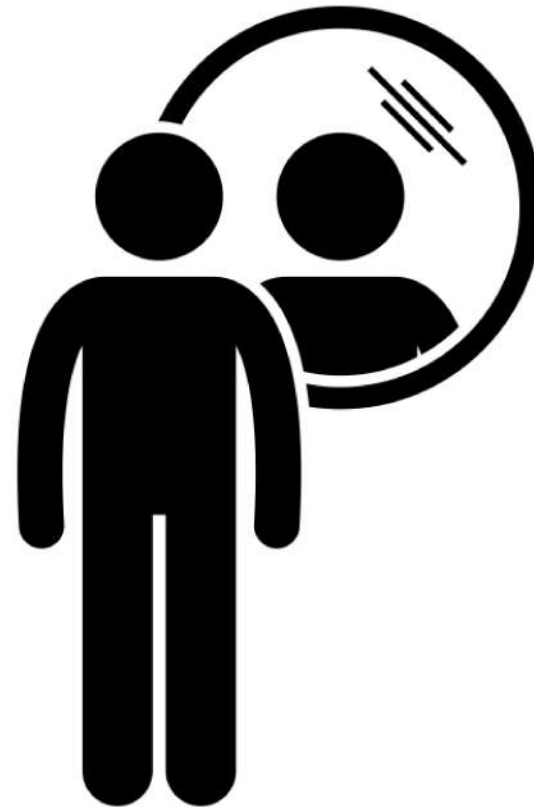

akcia - reakcia

VNÍMANIE

senzorické vnemy



sú subjektívne
no nie pasívne

PROBLÉM

ťažkosti s efektivitou
práce v domácom prostredí



krátkodobé sústredenie

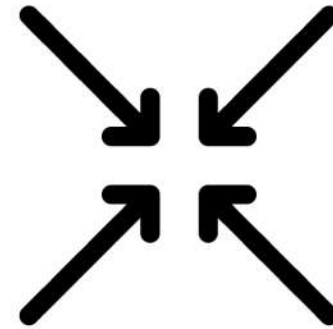

CIEĽ

usporiadanie
senzorických vnemov

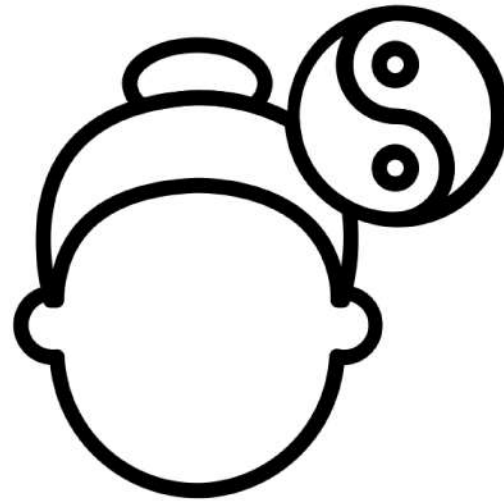

balans medzi

/prácou a relaxom
/akciou a komfortom

“zafixovanie” činnosti polohou

ANALÝZA VÍZIÍ

pretvára sa význam
vlastníť

trvanlivosť, flexibilita
použitia a účinnosť
produktu

návrat k nevyhnutnému

vyhnutie sa nadmernej
spotrebe

/minimalizmus
/flexibilné vlastníctvo

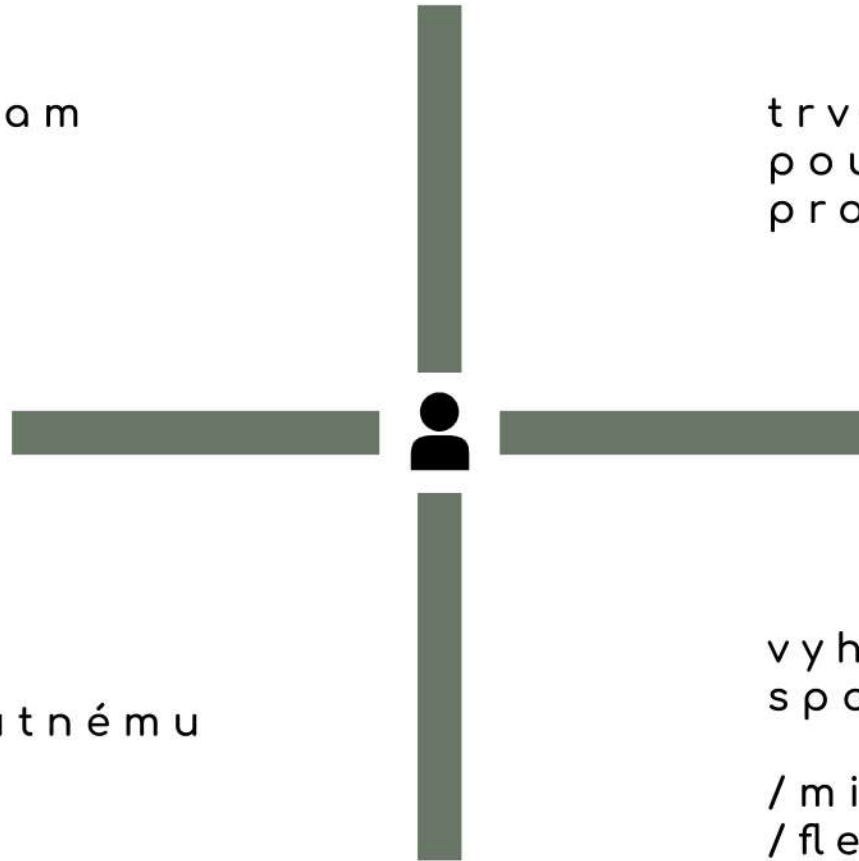

SKICE

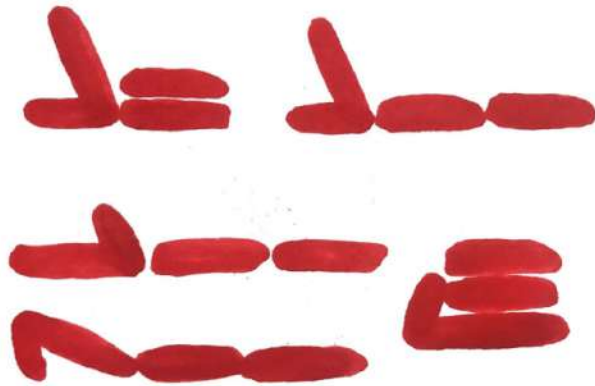
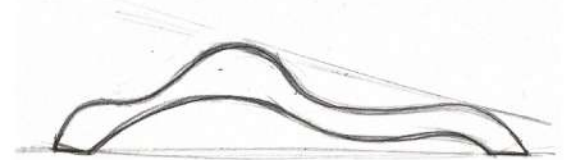
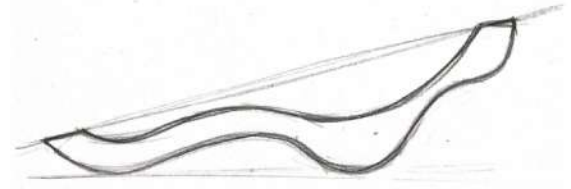
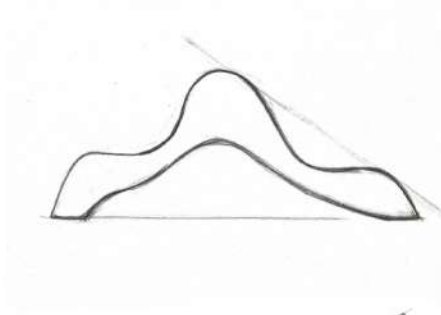
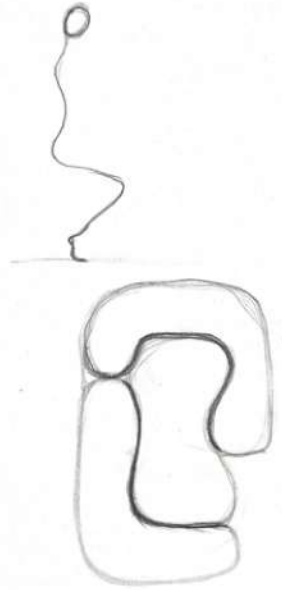
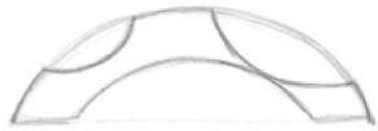
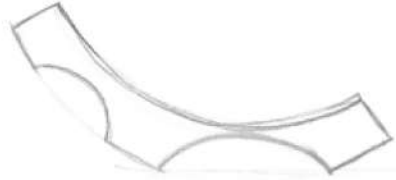
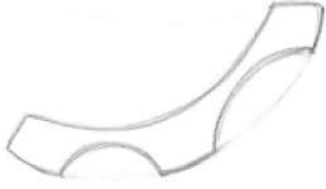

SKICE

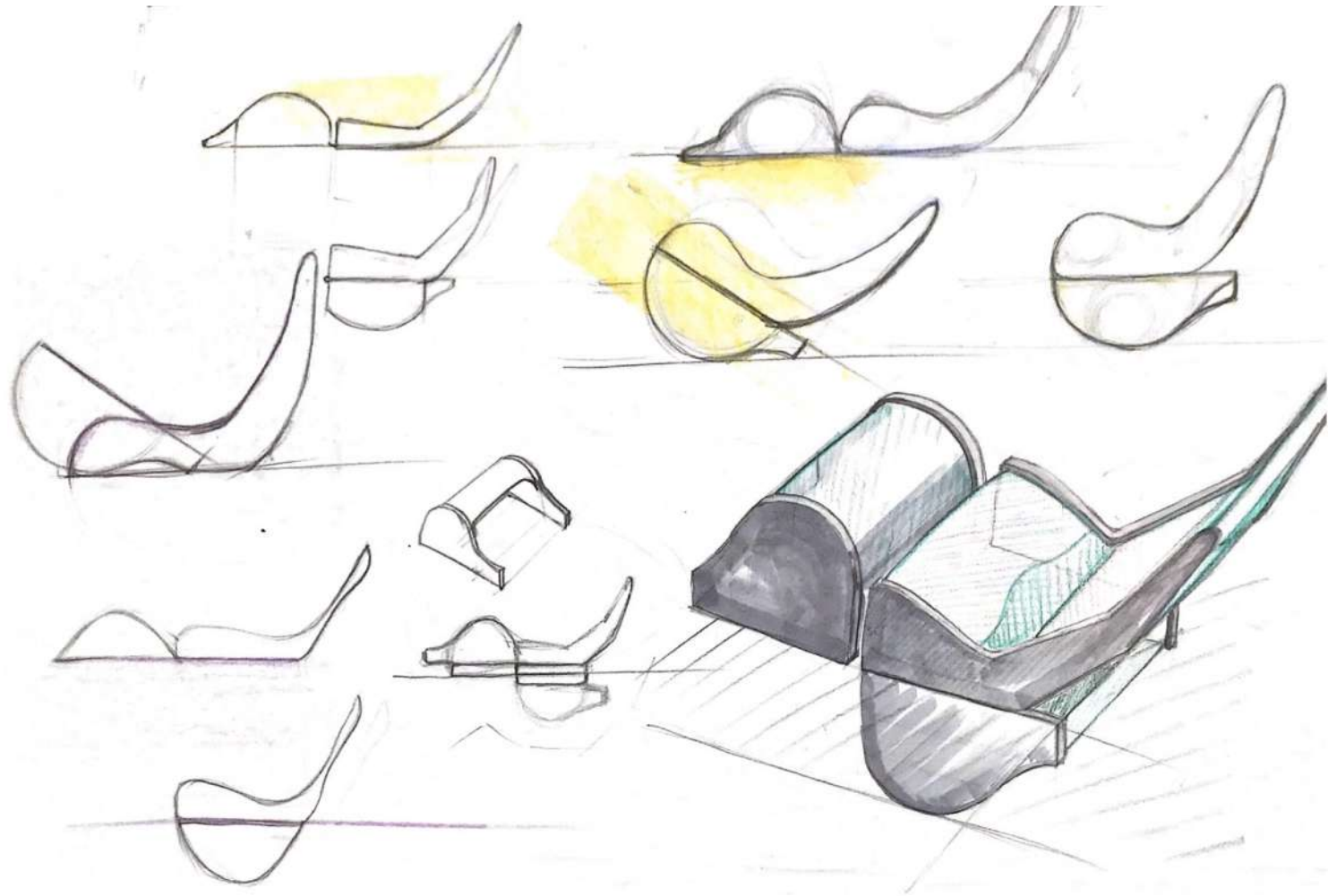
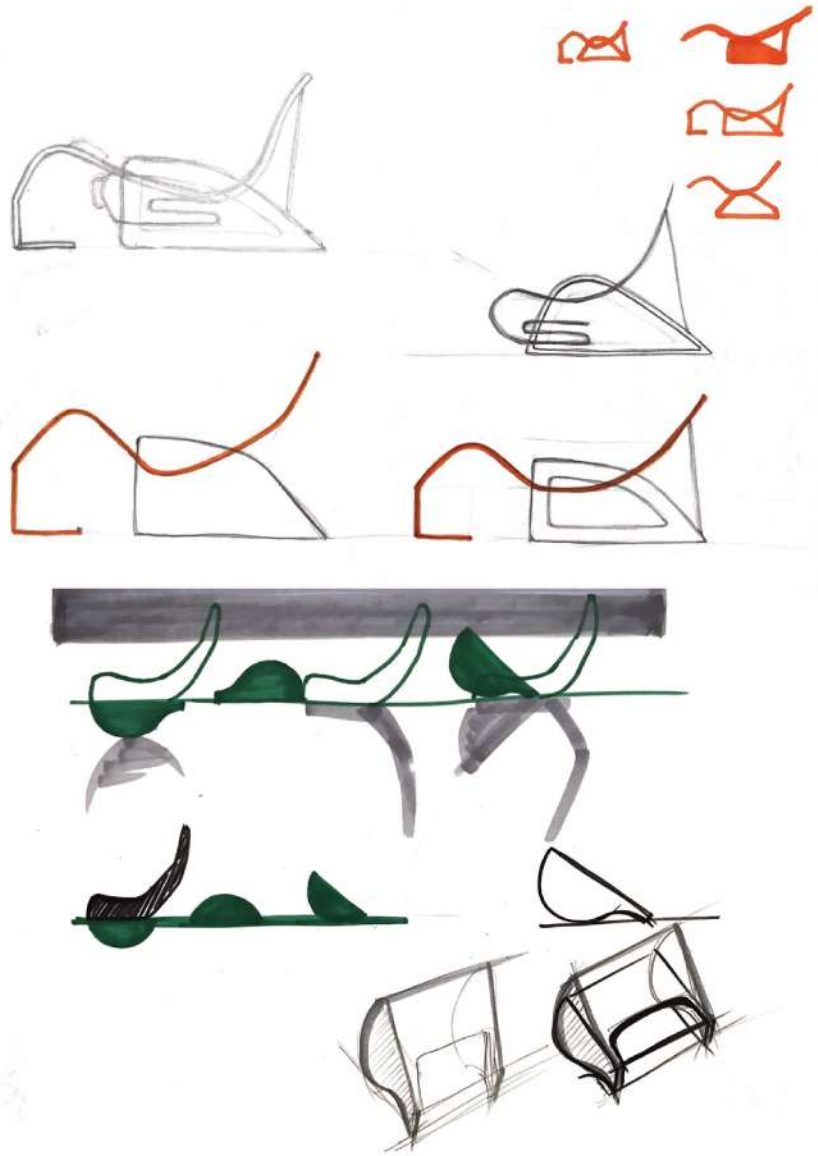

TESTING

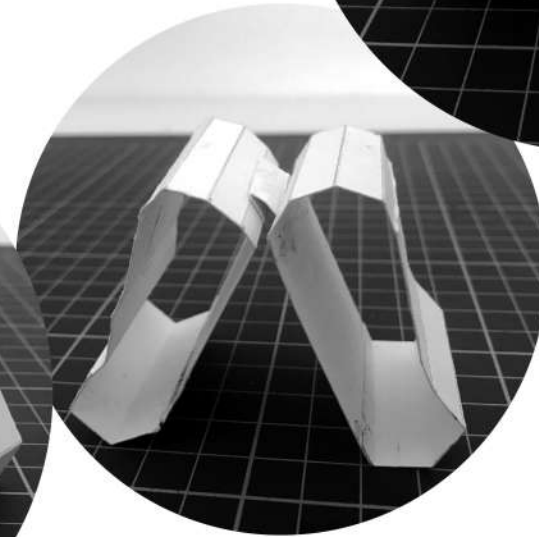
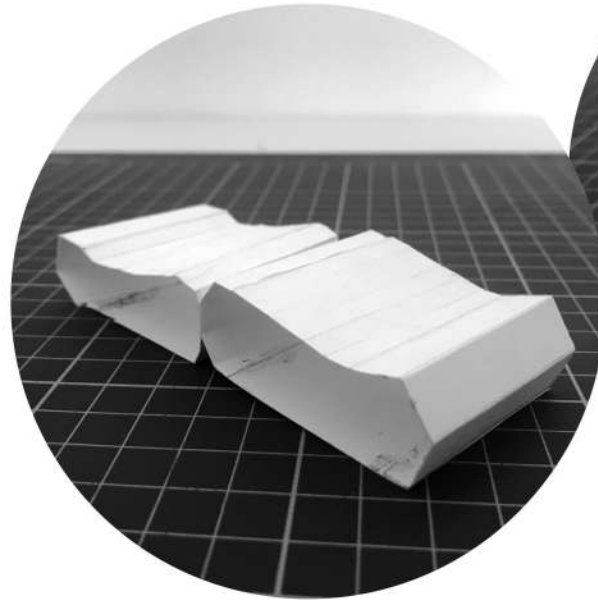
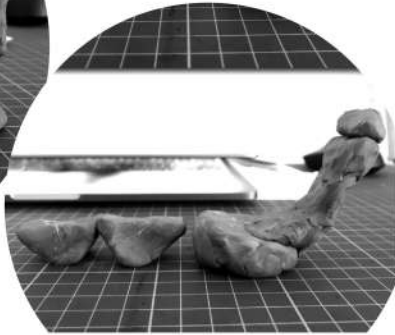
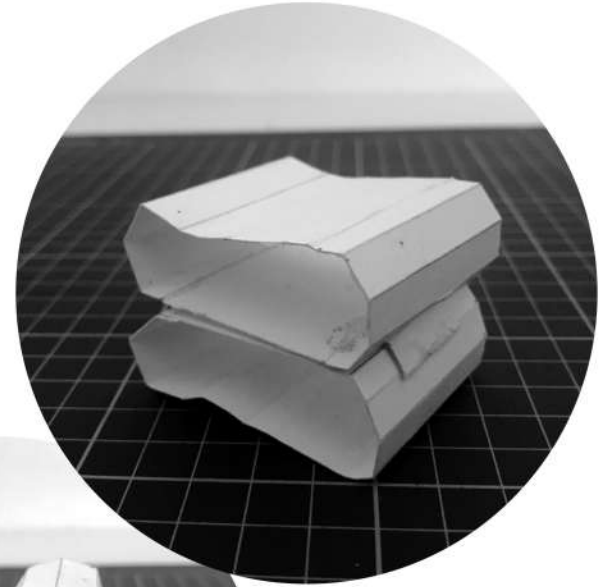
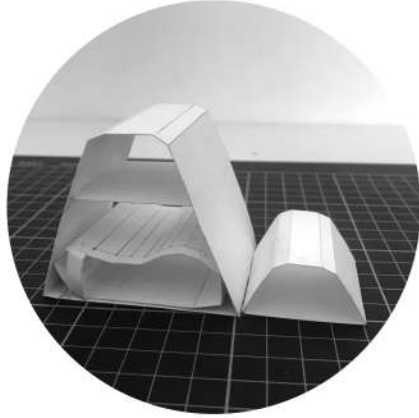

TESTING

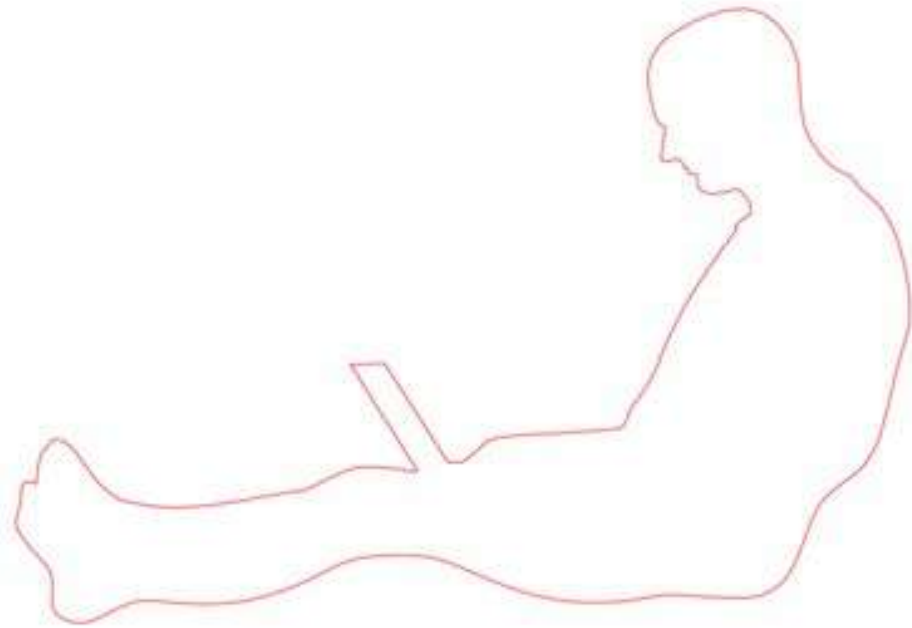

MODEL



POLOHA A



POLOHA B



POLOHA C



SEKUNDÁRNE VYUŽITIE

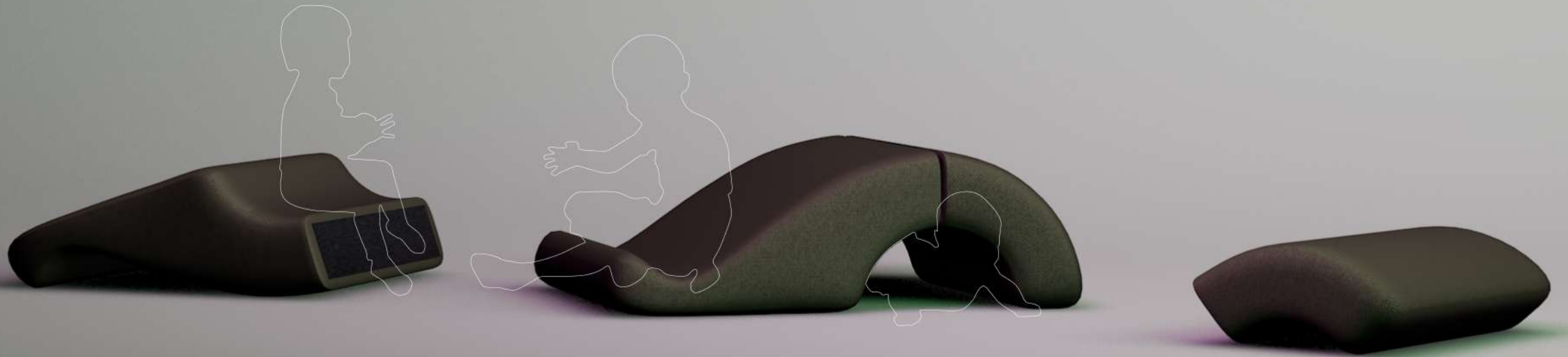

POHYB PRETÁČANIA

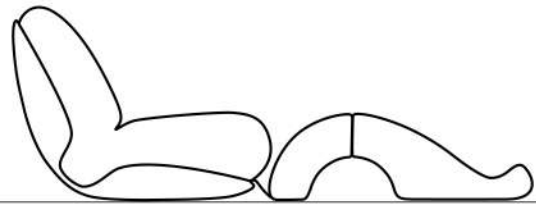

A

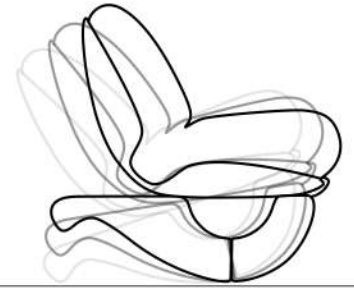

C

ROZMERY

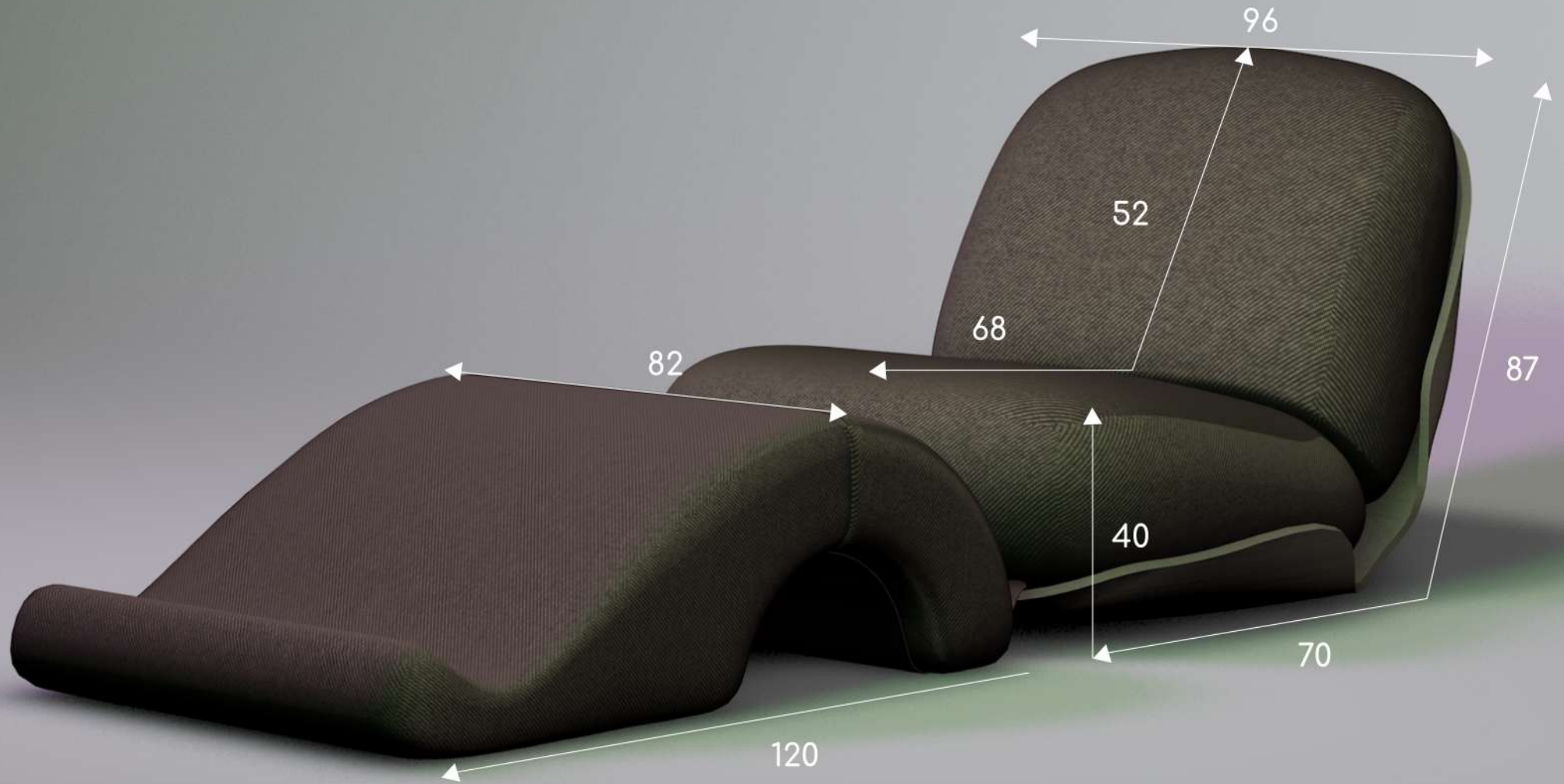

ROZMERY V REZE

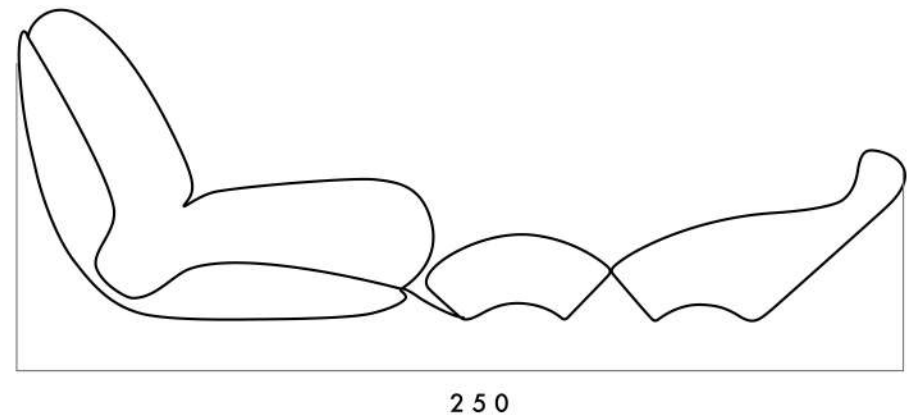
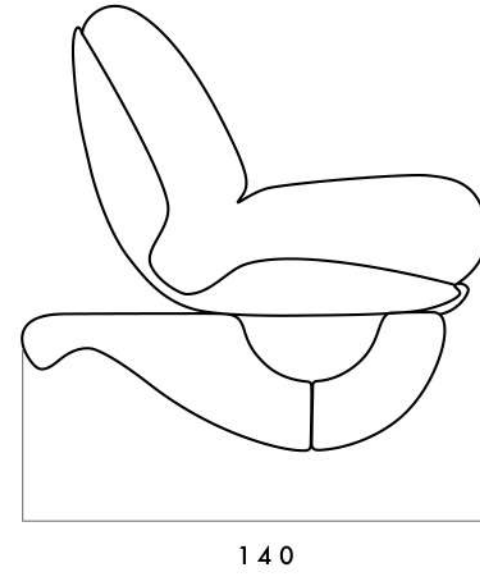
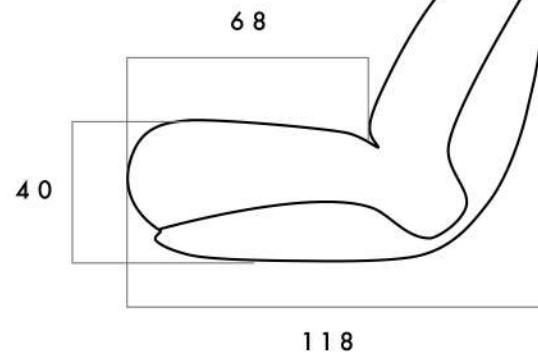
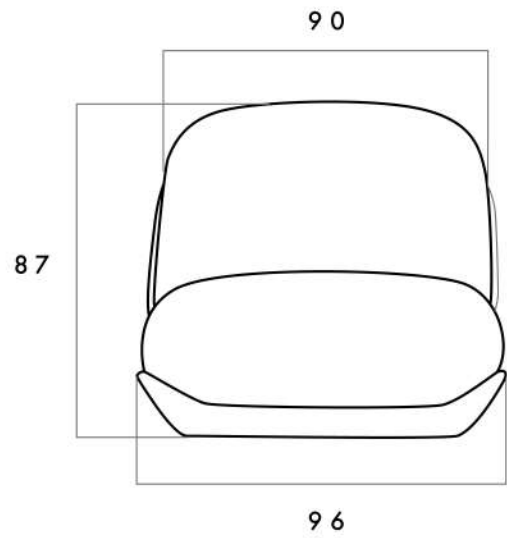

KONŠTRUKCIA

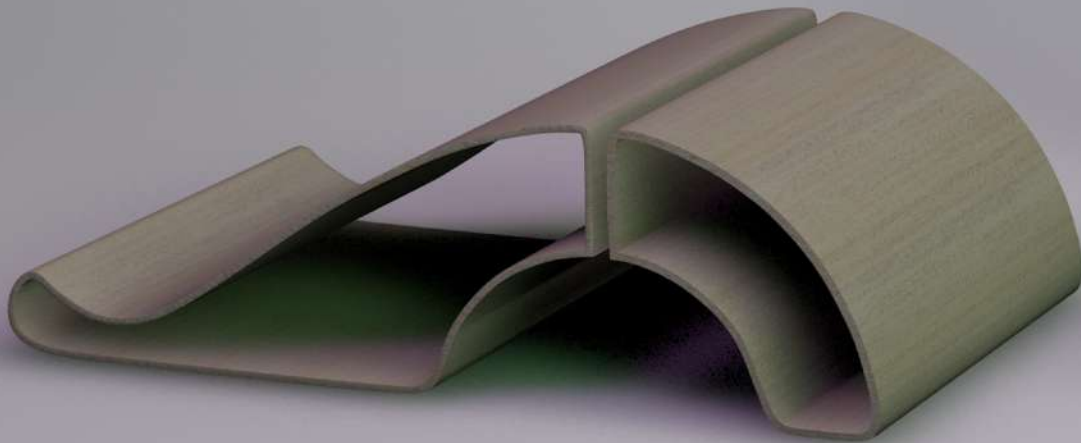
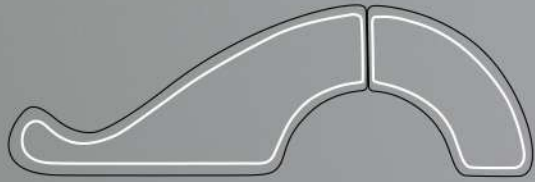

KONŠTRUKCIA



DETAILY

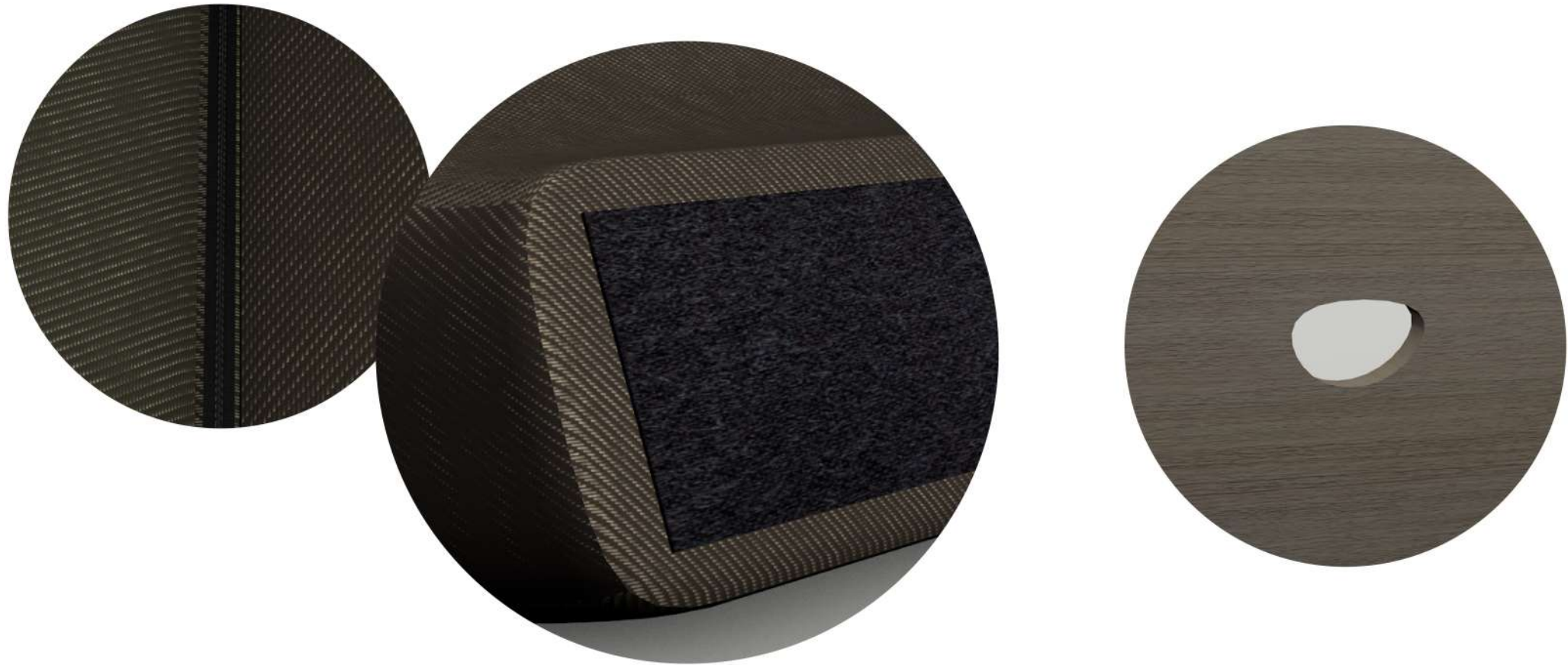

MATERIÁL



FAREBNÉ VARIÁCIE



ĎAKUJEM ZA POZORNOST